

Assembly Press

UFM Classic 3-100-120 / Art. No. 374003G2

Main functions	
Nominal force (push/pull)	3 / 3 kN
Stroke	100 mm
Nominal speed	120 mm/s
Nominal acceleration	2000 mm/s ²
Dwell time of nominal load	min. 4 s
Weight mechanics	15 kg
Max. tool weight*	2 kg
Force	
Measuring principle	DMS
System accuracy**	<1% with 2-point-calibration / <0,3% with characteristic map
Amplifier PDM-S / (WxHxD)	Aluminum die-cast / 125 x 80 x 57 mm
Output signal	digital
Protection class	IP40
Power supply	19...36 VDC (3 W)
Distance measuring	
Feedback device	Resolver
Repeatability of positioning***	< 0,01 mm
Servo amplifier	
Type	M702-034-00025-A
Dimensions (WxHxD)	83 x 382 x 200 mm
Mains voltage	3 AC 380 V ... 480 V, +/-10 %
Cable cross section (input)	IEC 1,5 mm ² / UL 18 AWG
Cable cross section (output)	IEC 1,5 mm ² / UL 18 AWG
Protection class (DIN 60529)	IP20
Weight	4 kg
Recommended protection	IEC 10 A gG UL/USA 10 A CC or J
Temperature range	-20 °C...+50 °C
Power loss	94 W
Line filter	
Weight	2 kg
Cable cross section (input)	4 mm ² / 12 AWG
Power loss	13 W
Dimensions (WxHxD)	83 x 426 x 41 mm
Protection class (DIN 60529)	IP20
Interfaces	
PC	Ethernet
PLC (24 VDC)	3I / 4O

Interfaces	
PLC Fieldbus	Profibus, Profinet, EtherCat, EtherNet/IP, Modbus/TCP
Extension Options PROMESS Bus	PDM-A: 4x analogue / PDM- P: Piezo / PDM-I/O: 16I / 16O

* if using a holding break: max. permitted tool weight = 10% nominal load. For a heavier tool weight please consult PROMESS.

** Force measuring system, static calibration in relation to the reference system / *** at thermal steady-state

All nominal values refer to 400 V mains voltage.

Tilting of the plunger due to the tool weight must be considered for a horizontal installation.

Radial forces must not exceed 8% of the nominal force of the unit.

If the ratio of pause time / cycle time is < 0,5, please consult PROMESS.

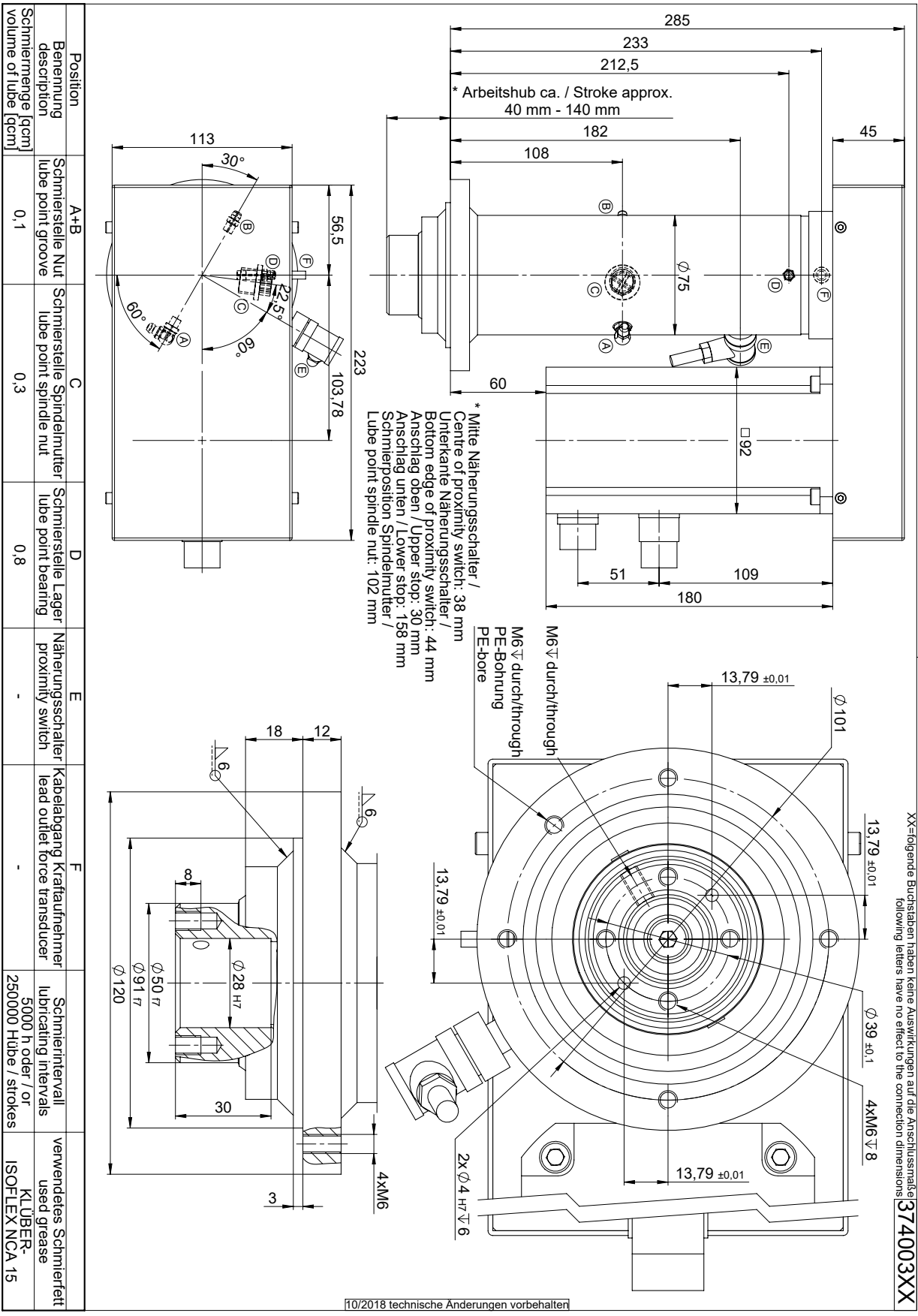

10/2018 technische Änderungen vorbehalten

XX-folgende Buchstaben haben keine Auswirkungen auf die Anschlussmaße 374003XX following letters have no effect to the connection dimensions