

Data sheet

Assembly Press

Assembly Press Line5 RX 60-350-250

Basic data	
Nominal force (push/pull)	60 / 60 kN
Stroke	350 mm
Nominal speed	250 mm/s
Nominal acceleration	1000 mm/s ²
Dwell time of nominal load	min. 4 s
Weight mechanics (HGX/SGX)	190,5 kg / 212,3 kg
Max. tool weight*	600 kg
Force measurement	
Measuring principle	Strain gauge (internal)
System accuracy**	<1% with 2-point-calibration / <0,3% with characteristic map
Preamplifier	
Type	PDM-S RX
Output signal	digital
Protection class	IP54
Power supply	24 VDC (-15 / +20 %)
Power input	14 W
Distance measuring	
Feedback device	Multiturn
Repeatability of positioning***	< 0,01 mm
Servo amplifier	
Type	M702-054-00270-A
Dimensions (WxHxD)	143 x 391 x 200 mm
Mains voltage	3 AC 380 V ... 480 V, +/-10 %
Cable cross section (input)	IEC 6 mm ² / UL 8 AWG
Cable cross section (output)	IEC 6 mm ² / UL 8 AWG
Protection class (DIN 60529)	IP20
Weight	7,4 kg
Recommended protection	IEC 35 A gG UL/USA 35 A CC or J
Temperature range	-20 °C...+50 °C
Power loss	356 W
Line filter	
Weight	4,2 kg
Cable cross section (input)	6 mm ² / 10 AWG

Line filter	
Power loss	47 W
Dimensions (WxHxD)	143 x 437 x 60 mm
Protection class (DIN 60529)	IP20
Controller	
Type	Controller RX
PLC Fieldbus	Profinet (RT), Profibus, EtherCAT, Ethernet/IP
Protection class	IP20
Power supply	24 VDC (-15 / +20 %) SELV
Power input	25 W

* For a heavier tool weight please consult PROMESS.

** Force measuring system, static calibration in relation to the reference system / ***at thermal steady-state

All nominal values refer to 400 V mains voltage.

Tilting of the plunger due to the tool weight must be considered for a horizontal installation.

Radial forces must not exceed 8% of the nominal force of the unit.

If the ratio of pause time / cycle time is < 0,5, please consult PROMESS.

Order code: RLWPK060D-035-025.G0

Type

R: Master UFM / S: Slave UFM / M: Press EMF

Model

L: Line5 RX / C: Classic
P: Precision5 RX

Engine manufacturer

W: Wittur

Motor position

I: Inline / P: Parallel / U: Parallel with machine protection coupling

Nominal force

N: N / K: kN / M: MN

Force measuring

D: DMS / P: Piezo / N: without

Nominal stroke in cm

Nominal speed in cm/s

Brake

H: Holding brake / S: Safety brake

Version number

G: Basic version

For more efficiency.

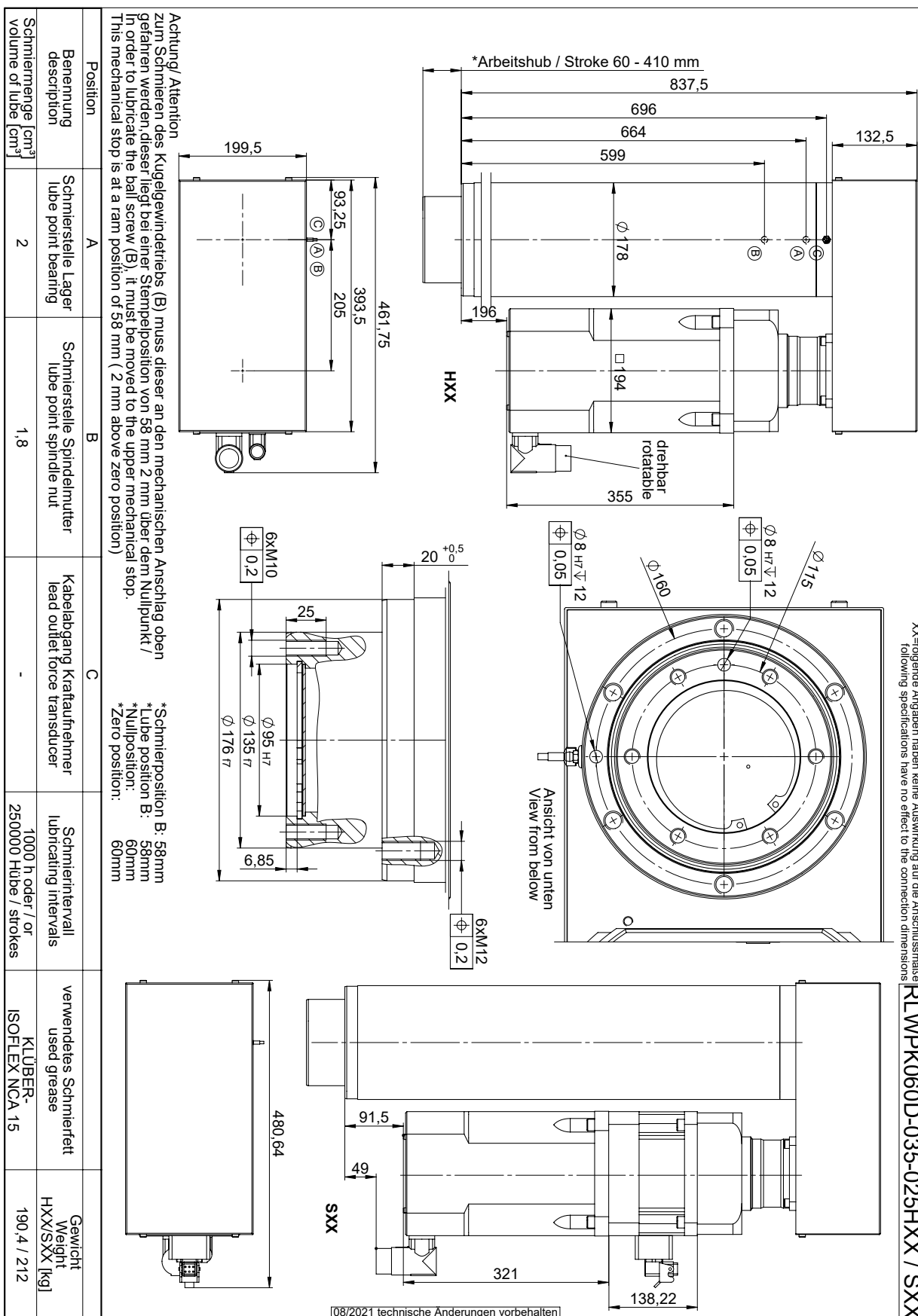

XX=folgende Angaben haben keine Auswirkung auf die Anschlussmaße
 following specifications have no effect to the connection dimensions
RLWPK060D-035-025HXX / SXX

Position	A	B	C		
Benennung description	Schmierstelle Lager lube point bearing	Schmierstelle Spindelmutter lube point spindle nut	Kabelabgang Kraftaufnehmer lead outlet force transducer	Schmierintervall lubricating intervals	verwendetes Schmierfett used grease
Schmiermenge [cm ³] volume of lube [cm ³]	2	1,8	-	1000 h oder / or 250000 Hübe / strokes	KLÜBER- ISOFLEX NCA 15
					Gewicht Weight HXXSXX [kg]
					190,4 / 212

Achtung/ Attention
 zum Schmieren des Kugelgewindetriebs (B) muss dieser an den mechanischen Anschlag oben
 gefahren werden, dieser liegt bei einer Stempelposition von 58 mm 2 mm über dem Nullpunkt /
 In order to lubricate the ball screw (B) it must be moved to the upper mechanical stop.
 This mechanical stop is at a ram position of 58 mm (2 mm above zero position)

*Schmierposition B: 58mm
 *Lube position B: 58mm
 *Nullposition: 60mm
 *Zero position: 60mm