

Data sheet

Assembly Press

UFM Line5s RX003-200-200

Basic data	
Nominal force (push/pull)	3 / 3 kN
Stroke	200 mm
Nominal speed	200 mm/s
Nominal acceleration	1000 mm/s ²
Dwell time of nominal load	min. 4 s
Weight mechanics (HGX/SGX)	8,8 kg
Max. tool weight*	30 kg
Force measurement	
Measuring principle	Strain gauge (internal)
System accuracy**	<1% with 2-point-calibration
Preamplifier	
Type	PDM-S RX
Output signal	digital
Protection class	IP54
Power supply	24 VDC (-15 / +20 %)
Power input	14 W
Distance measuring	
Feedback device	Multiturn
Repeatability of positioning***	< 0,01 mm
Servo amplifier	
Type	M702-034-00025-A
Dimensions (WxHxD)	83 x 382 x 200 mm
Mains voltage	3 AC 380 V ... 480 V, +/-10 %
Cable cross section (input)	IEC 1,5 mm ² / UL 18 AWG
Cable cross section (output)	IEC 1,5 mm ² / UL 18 AWG
Protection class (DIN 60529)	IP20
Weight	4 kg
Recommended protection	IEC 10 A gG UL/USA 10 A CC or J
Temperature range	-20 °C...+50 °C
Power loss	94 W
Line filter	
Weight	2 kg
Cable cross section (input)	4 mm ² / 12 AWG
Power loss	13 W
Dimensions (WxHxD)	83 x 426 x 41 mm

Line filter	
Protection class (DIN 60529)	IP20
Controller	
Type	Controller RX
PLC Fieldbus	Profinet (RT), Profibus, EtherCAT, Ethernet/IP
Protection class	IP20
Power supply	24 VDC (-15 / +20 %) SELV
Power input	25 W

* For a heavier tool weight please consult PROMESS.

** Force measuring system, static calibration in relation to the reference system / ***at thermal steady-state

All nominal values refer to 400 V mains voltage.

Tilting of the plunger due to the tool weight must be considered for a horizontal installation.

Radial forces must not exceed 8% of the nominal force of the unit.

If the ratio of pause time / cycle time is < 0,5, please consult PROMESS.

Order code: **RLWIK003D-020-020HGO**

Type

R: Master UFM / S: Slave UFM / M: Press EMF

Model

L: Line5 RX / C: Classic
P: Precision5 RX

Engine manufacturer

W: Wittur

Motor position

I: Inline / P: Parallel / U: Parallel with machine protection coupling

Nominal force

N: N / K: kN / M: MN

Force measuring

D: DMS / P: Piezo / N: without

Nominal stroke in cm

Nominal speed in cm/s

Brake

H: Holding brake / S: Safety brake

Version number

G: Basic version

For more efficiency.

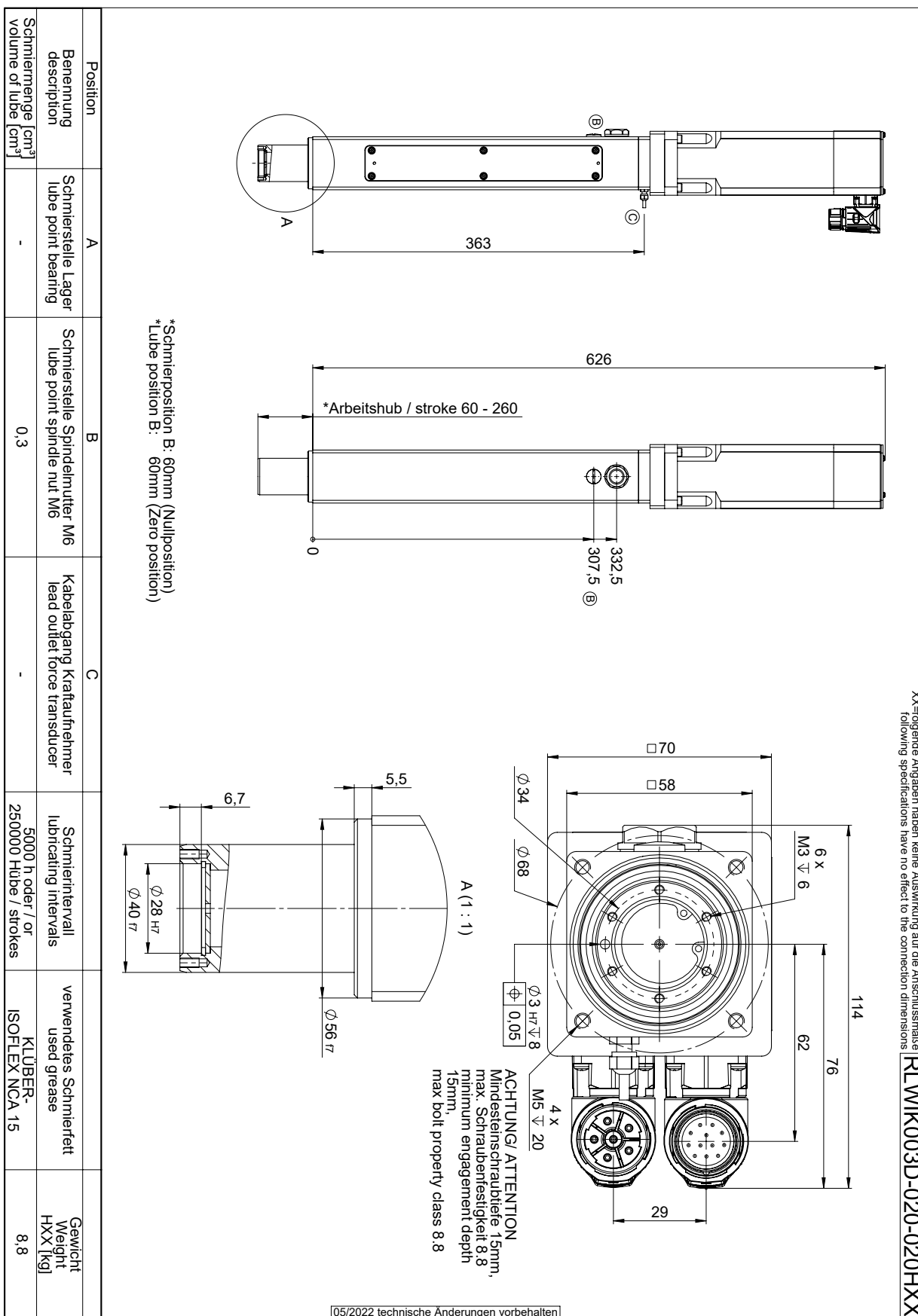

XX=folgende Angaben haben keine Auswirkung auf die Anschlussmaße
 following specifications have no effect to the connection dimensions

RLWIK003D-020-020HXX