

## Assembly Press

### Assembly Press Line5 Inline 30-550-250

Main functions	
Nominal force (push/pull)	30 / 30 kN
Stroke	550 mm
Measurement ranges	9/10/11/13/15/18/21/24/27/30 kN
Nominal speed	250 mm/s
Nominal acceleration	1000 mm/s <sup>2</sup>
Dwell time of nominal load	min. 4 s
Weight mechanics (HGX/SGX)	104,2 / 117,3 kg
Max. tool weight*	20 kg

Force	
Measuring principle	DMS
System accuracy**	<1% with 2-point-calibration / <0,3% with characteristic map
Range accuracy	<1% of measurement range
Amplifier PDM-S / (WxHxD)	Aluminum die-cast / 125 x 80 x 57 mm
Output signal	digital
Protection class	IP40
Power supply	19...36 VDC (3 W)

Distance measuring	
Feedback device	Multiturn
Repeatability of positioning***	< 0,01 mm

Servo amplifier	
Type	M702-034-00100-A
Dimensions (WxHxD)	83 x 382 x 200 mm
Mains voltage	3 AC 380 V ... 480 V, +/-10 %
Cable cross section (input)	IEC 2,5 mm <sup>2</sup> / UL 12 AWG
Cable cross section (output)	IEC 2,5 mm <sup>2</sup> / UL 12 AWG
Protection class (DIN 60529)	IP20

Servo amplifier	
Weight	4,5 kg
Recommended protection	IEC 20 A gG UL/USA 20 A CC or J
Temperature range	-20 °C...+50 °C
Power loss	209 W

Line filter	
Weight	2 kg
Cable cross section (input)	4 mm <sup>2</sup> / 12 AWG
Power loss	13 W
Dimensions (WxHxD)	83 x 426 x 41 mm
Protection class (DIN 60529)	IP20

Interfaces	
PC	Ethernet
PLC (24 VDC)	3I / 4O
PLC Fieldbus	Profibus, Profinet, EtherCat, EtherNet/IP, Modbus/TCP
Extension Options PROMESS Bus	PDM-A: 4x analogue / PDM-P: Piezo / PDM-I/O: 16I / 16O

\* if using a holding brake: max. permitted tool weight = 10% nominal load. For a heavier tool weight please consult PROMESS.

\*\* Force measuring system, static calibration in relation to the reference system / \*\*\* at thermal steady-state

All nominal values refer to 400 V mains voltage.

Tilting of the plunger due to the tool weight must be considered for a horizontal installation.

Radial forces must not exceed 8% of the nominal force of the unit.

If the ratio of pause time / cycle time is < 0,5, please consult PROMESS.

Order code: **LN5 I 0300-055-025 ... ..**

#### Motor position

I: Inline / P: Parallel

Nominal force in 1/10 kN

Nominal stroke in cm

Nominal speed in cm/s

#### Brake:

H: Holding brake / S: Safety brake

N: without brake

#### Special type:

GX: Basic version / XX: Special type

For more efficiency.

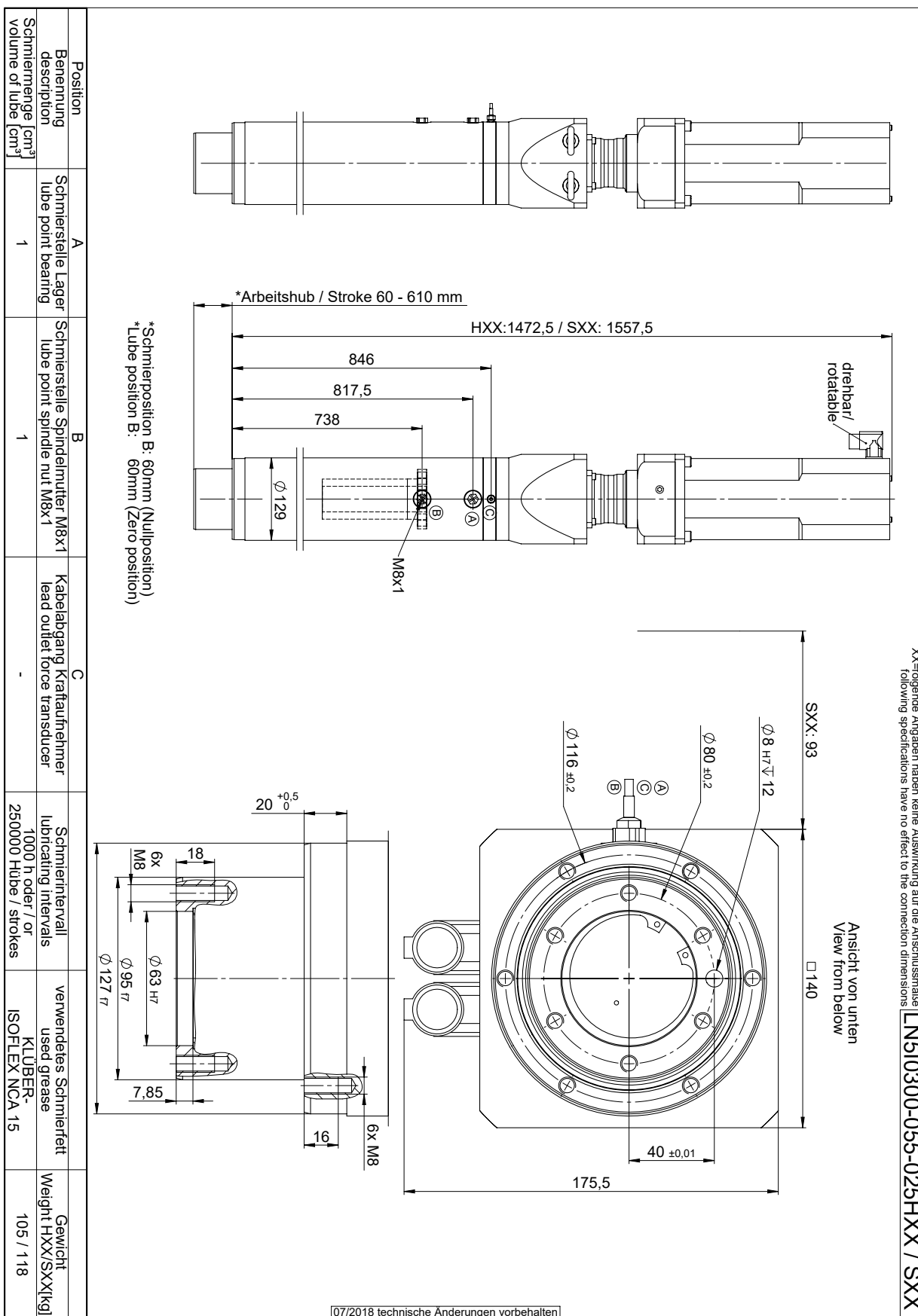

07/2018 technische Änderungen vorbehalten

Position Benennung description	A	B	C			
Schmierstelle Lager lube point bearing	1					
Schmierstelle Spindelmutter M8x1 lube point spindle nut M8x1		1				
Kabelabgang Kraftaufnehmer lead outlet force transducer						
Schmierintervall lubricating intervals				1000 h oder / or 250000 Hübe / strokes		
verwendetes Schmierfett used grease					KLUBER- ISOFLEX NCA 15	
Gewicht Weight HXX/SXX[kg]						105 / 118